



Specification

Nominal Voltage	12V
Number of cell	6
Design Life	10 years
Nominal Capacity 77°F(25°C)	
20hour rate (10A, 10.5V)	200AH
10hour rate (19.1A, 10.5V)	191AH
5 hour rate (34.5A, 10.5V)	173AH
1 hour rate (132A, 9.6V)	132AH
Internal Resistance	
Fully Charged battery 77°F(25°C)	3.5mOhms
Self-Discharge	
3% of capacity declined per month at 20°C(average)	
Operating Temperature Range	
Discharge	-30~60°C
Charge	-20~60°C
Storage	-30~60°C
Max. Discharge Current 77°F(25°C)	1000A(5s)
Short Circuit Current	3300A
Charge Methods: Constant Voltage Charge 77°F(25°C)	
Cycle use	14.4-14.7V
Maximum charging current	60A
Temperature compensation	-30mV/°C
Standby use	13.6-13.8V
Temperature compensation	-20mV/°C

General Features

- Silica gel technology for longer cycle life and better performance at cold ambient temperatures.
- Special sheet separator and colloidal or foamed silica.
- Deep discharge cycle increased by 50% as compared with the AGM battery.
- High reliability and quality.
- Excellent recovery from deep discharge.
- Living up prevailing standards.

Dimensions and Weight

Length(mm / inch)	522 / 20.55
Width(mm / inch)	238 / 9.37
Height(mm / inch)	223/8.78
Total Height(mm / inch)	223/8.78
Approx. Weight(Kg / lbs)	66 / 145.5
Standard Terminal	I

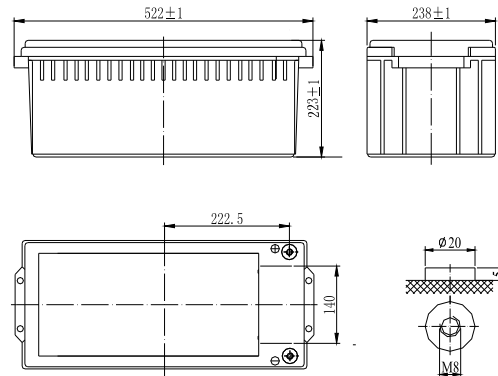

Discharge Constant Current (Amperes at 77°F25°C)

End Point Volts/Cell	5min	10min	15min	30min	1h	3h	5h	10h	20h
1.60V	700	480	350	210	132	54.6	38.2	19.6	10.40
1.65V	630	438	340	204	131	54.4	36.8	19.4	10.30
1.70V	598	422	328	200	131	54.2	35.4	19.3	10.10
1.75V	532	390	310	196	130	54.0	34.5	19.1	10.00
1.80V	480	362	296	190	128	53.8	34.2	19.0	9.84

Discharge Constant Power (Watts at 77°F25°C)

End Point Volts/Cell	5min	10min	15min	30min	1h	3h	5h	10h	2h
1.60V	1154	796	620	396	260	105	74.0	42.4	72.1
1.65V	1094	786	614	388	251	104	73.5	41.8	71.5
1.70V	1022	766	604	378	244	103	73.0	41.4	70.9
1.75V	952	716	568	368	242	102	72.2	40.8	70.4
1.80V	854	666	534	358	238	101	71.0	40.0	69.8

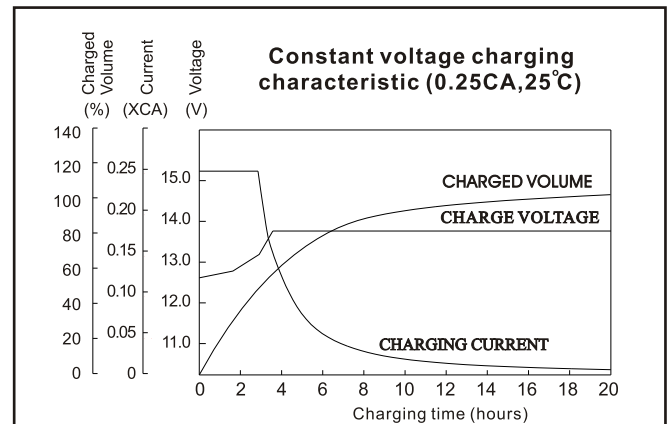
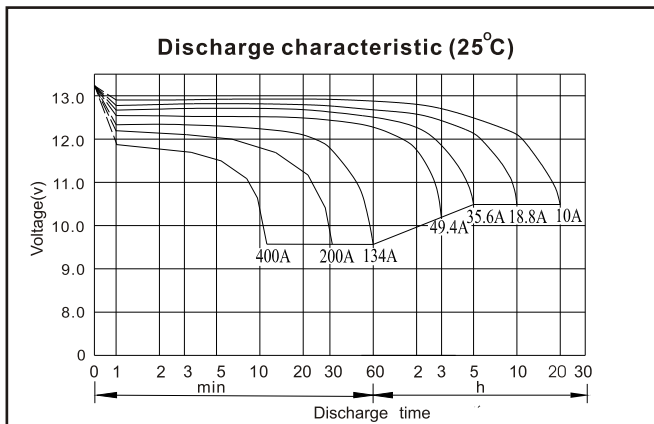

Specification

